

LES BATTANTS

Parcelle Section C N°2180 & N°1736
13 678m²

----- Limite de propriété

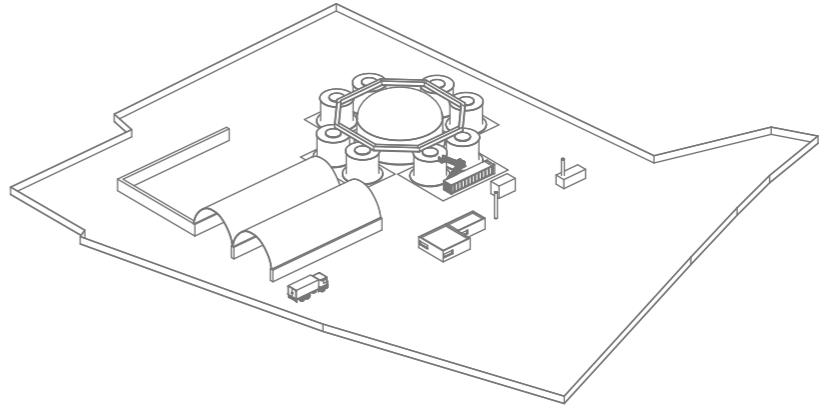

**Unité de Méthanisation
Rue Auguste Lambiotte, 58700 PREMERY**

<h1>PLAN DE CADASTRE</h1>	ECH: 1:2000	N°: 01b
	DATE: 06/12/2016	

Maître d'Ouvrage:	Hélioprod Prémery 39, avenue George V 75008 PARIS	T : 01.58.56.22.44 F : 01.58.56.22.43 marie.verdoux@fulton.fr
-------------------	---	---

Architectes :	AGAPE 40 rue Lauriston 75 116 PARIS 41 rue d'Iena 76 600 LE HAVRE	T: 01.42.71.92.22 b.andrier@agape-architectes.fr j.botella@agape-architectes.fr
---------------	---	---

BET VRD ORLING Olivier Brunetaud o.brunetaud@orling.fr T: 02.38.56.14.97 82 rue du Clos Pasquies 45655 SAINT JEAN LE BLANC	
---	--

Modification:	Date: